

Solar Power Smart Waste Bin

¹Mr. Jobin francis, ²Mr. Melbin TL, ³Mr. Praveen CN

^{1,2,3}Vimal Jyothi Engineering College, Chemperi Kannur

Abstract: - India government recently introduced a new campaign named “SWACH BHARATH” that is aiming to make our country clean and tidy. That is, now the condition of our country is very bad in the field of waste management. There are many waste bins in our cities and country sides. But the reality is nobody using it in an effective way. As we all saw that in cities and streets the waste bin is there and all the wastes are near its side. The reason for this is, if one person deposit the waste outside of it, the person next coming to their will automatically throws the waste outside of the basket. This will continues. Our intention is to approach this problem in a different manner. If the lid of the waste bin opens automatically, when a person approaches to the waste bin then the person automatically deposit the waste inside it. No one has a tendency to throw the garbage outside the basket. That is our project “SOLAR POWERED SMART WASTE BIN “which is aimed to make our cities and streets clean and tidy.

Keywords – solar powering, automatic, waste bin, ultra sonic

I. INTRODUCTION

In the present stage the waste management is the main problem which is seemed in the towns and other places. Present stage is consisting of waste bin which is without having the lid on top. So it is after filling become dirtier and the wastes will be near to that. So the people will have a negative impression and they are not willing to put waste inside the waste bin. So we are implementing a new system which having high role in the social cleaning. Our system is consist of automated waste bin with entire power is from the renewable solar energy. The smart waste bin will detect the presence of people and automatically opens the lid and it accepts the waste. After the person leave the area the system closes the lid. As mentioned above the system is working in solar energy it require voltage regulation for charging the battery because solar energy is highly fluctuating in nature. Solar cell will change the values in accordance with the solar energy falling on it. The circuit of our proposed project has two parts:

(i) Solar energy powering part (ii) waste bin part

A. Components Required

Hardware components comprises of the following:-

- AVR atmega 328
- Ultra sonic sensor[HC-SR04]
- Stepper motor
- Solar panel
- Battery
- LED
- Resistors
- Capacitors
- Diodes
- Switch
- Crystal Oscillator
- Buzzer

Software Components: Software components comprises of the following:-

- Arduino programming software
- Assembly language

Introduction to Embedded Systems

1) Definition: Embedded System Any sort of device which includes a programmable computer, but itself is not intended to be a general-purpose computer.

2) What is an Embedded System An embedded system is a microcontroller / digital signal microprocessor based system that is designed to be flexible and built to control or monitor the functions of equipment, machinery, plant and many devices in common use today.

II.METHODOLOGY

A. Block Diagram

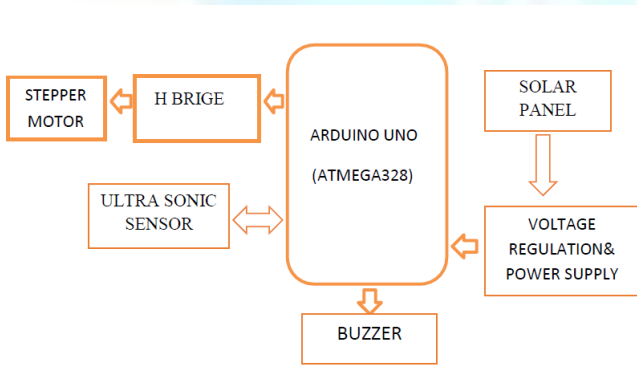

The core of our proposed Smart waste bin scheme basically consists of an ultrasonic sensor that functions as the distance calculator. The ultrasonic sensor will be attached to waste bin which is placed in public areas. The ultrasonic sensor continuously measure the distance in front of the bin and if the distance fall below a particular value the presence of humans can be identified. At this time the H Bridge can be activated and lid can be opened, a buzzer can be activated for indicating the operation.

This system is entirely working in renewable solar energy. Since the solar energy is highly fluctuating voltage regulator circuit is used for making a constant supply of voltage to charge the battery. LM317 voltage regulator is used for in the circuit for the above purpose. The aforementioned functionality has been achieved by interfacing the ultrasonic sensor modules with the ATMEGA328 microcontroller on-

board the Arduino Uno board. The Arduino integrated development environment is an open-source project which simplified the coding greatly.

B. Detailed Description

C. Arduino uno (Programmable System on-Chip)

The Arduino Uno is a microcontroller board based on the ATmega328. It has 14 digital input/output pins (of which 6 can be used as PWM outputs), 6 analog inputs, a 16 MHz ceramic resonator, a USB connection, a power jack, an ICSP header, and a reset button. It contains everything needed to support the microcontroller; simply connect it to a computer with a USB cable or power it with a AC-to-DC adapter or battery to get started. The Uno differs from all preceding boards in that it does not use the FTDI USB-to-serial driver chip. Instead, it features the Atmega16U2 (Atmega8U2 up to version R2) programmed as a USB-to-serial converter. Revision 2 of the Uno board has a resistor pulling the 8U2 HWB line to ground, making it easier to put into DFU mode. Revision 3 of the board has the following new features:

- Pinout: added SDA and SCL pins that are near to the AREF pin and two other new pins placed near to the RESET pin, the IOREF that allow the shields to adapt to the voltage provided from the board. In future, shields will be compatible both with the board that use the AVR, which operate with 5V and with the Arduino Due that operate with 3.3V. The second one is a not connected pin that is reserved for future purposes.
- Stronger RESET circuit.
- Atmega 16U2 replace the 8U2.

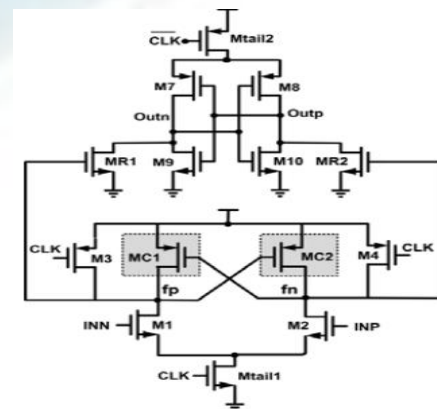



III. ULTRASONIC RANGING MODULE HC – SR04

Ultrasonic ranging module HC - SR04 provides 2cm - 400cm non-contact measurement function, the ranging accuracy can reach to 3mm. The module includes ultrasonic transmitters, receiver and control circuit. The basic principle of work:

- (1) Using IO trigger for at least 10us high level signal,
- (2) The Module automatically sends eight 40 kHz and detect whether there is a pulse signal back.
- (3) IF the signal back, through high level , time of high output IO duration is the time from sending ultrasonic to returning. Test distance = (high level time×velocity of sound (340M/S) / 2.

- 5V Supply
- Trigger Pulse Input
- Echo Pulse Output
- Ground

MOTOR DRIVER LM298N

The Device is a monolithic integrated high voltage, high current four channel driver designed to accept standard DTL or TTL logic levels and drive inductive loads (such as relays solenoids, DC and stepping motors) and switching power transistors. To simplify use as two bridges each pair of channels is equipped with an enable input. A separate supply

input is provided for the logic, allowing operation at a lower voltage and internal clamp diodes are included. This device is suitable for use in switching applications at frequencies up to 5 kHz.

STEPPER MOTOR [bi-polar]

Bipolar motors have a single winding per phase. The current in a winding needs to be reversed in order to reverse a magnetic pole, so the driving circuit must be more complicated, typically with an H-bridge arrangement (however there are several off-the-shelf driver chips available to make this a simple affair). There are two leads per phase, none are common. Because windings are better utilized, they are more powerful than a unipolar motor of the same weight. This is due to the physical space occupied by the windings. A unipolar motor has twice the amount of wire in the same space, but only half used at any point in time, hence is 50% efficient (or approximately 70% of the torque output available). Though a bipolar stepper motor is more complicated to drive, the abundance of driver chips means this is much less difficult to achieve.

BUZZER

Piezoelectric buzzers, or piezo buzzers, as they are sometimes called, were invented by Japanese manufacturers and fitted into a wide array of products during the 1970s to 1980s. This advancement mainly came about because of cooperative efforts by Japanese manufacturing companies. In 1951, they established the Barium Titanate Application Research Committee, which allowed the companies to be "Competitively cooperative" and bring about several piezoelectric innovations and inventions.

VOLTAGE REGULATOR (LM 317)

The LM317 device is an adjustable three-terminal positive-voltage regulator capable of supplying more than 1.5A over an output-voltage range of 1.25 V to 37 V. It requires only two external resistors to set the output voltage. The device features a typical line regulation of 0.01% and typical load regulation of 0.1%. It includes current limiting, thermal overload protection, and safe operating area protection. Overload protection remains functional even if the adjust terminal is disconnected.

The LM317 device is versatile in its applications,

including uses in programmable output regulation and local on card regulation. Or, by connecting a fixed resistor between the ADJUST and OUTPUT terminals, the LM317 device can function as a precision current regulator. An optional output capacitor can be added to improve transient response. The ADJUST terminal can be bypassed to achieve very high ripple-rejection ratios, which are difficult to achieve with standard three-terminal regulators.

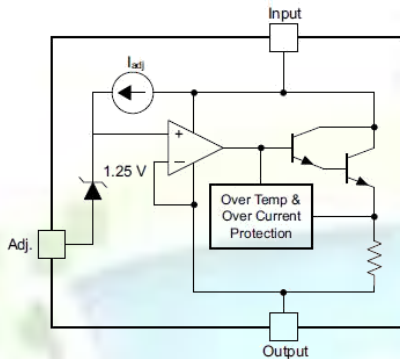

IV. SOLAR PANNEL

Quality solar panels with high efficiency and smaller footprint compared to our regular monocrystalline models. An easy way to keep your 12V batteries topped up and ready to go on your caravan, farm equipment, the spare car, or on the shed out the back. The dust and weather resistant panel features a robust frame, and is supplied with 3m long leads terminated with battery clips. Each version is fitted with a blocking diode, so they are suitable for direct connection to your battery as a trickle charger (take note of the minimum battery capacity), or as a low current charger to replace a load or current drain on the battery. A charge controller such as AA0348 is recommended on the 10W and 20W versions when there is not enough current drain to prevent over-charging of the battery.

C) WORKING

Our proposed Smart waste bin project basically consists of two parts, a ultrasonic sensor that functions as the distance calculator and the solar powering part. The ultrasonic sensor will be attached to waste bin which is placed in public areas. The ultrasonic sensor continuously measure the distance in front of the bin and if the distance fall below a particular value the presence of humans can be

identified. At this time the H Bridge can be activated and lid can be opened, a buzzer can be activated also for indicating the operation. The system will make beep sound to indicate the waste bin presence to the passengers who are approaching the system. This system is entirely working in renewable solar energy. Since the solar energy is highly fluctuating voltage regulator circuit is used for making a constant supply of voltage to charge the battery. LM317 voltage regulator is used for in the circuit for the above purpose. The aforementioned functionality has been achieved by interfacing the ultrasonic modules with the ATMEGA328 microcontroller on-board the Arduino Uno board.

V. CONCLUSION

This project is a cost effective and it has high social impact. This system changes the traditional systems and makes the revolution in waste management

REFERENCES

- [1] [http:// www.arduino.cc](http://www.arduino.cc)
- [2] <http://www.datasheetcatalog.com>
- [3] <http://www.instructables.com>
- [4] <http://www.wikipedia.com>
- [5] Electronic Circuit and Devices by J.B Gupta
- [6] Von Meier, Alexandra (2006). Electric Power Systems: A Conceptual Introduction. Wiley-IEEE.