

Android controlled Smart Car

¹Jayesh George M, ²Adithya Sreyaj P P, ³Daniel Joseph, ⁴Sajeer P

^{1,2,3,4}Vimal Jyothi Engineering College, Chemperi Kannur

Abstract: A car is usually an electro-mechanical machine that is guided by computer and electronic programming. The car which can be controlling using an APP for android mobile. We are developing the remote buttons in the android app by which we can control the car motion with them. Here we use Bluetooth communication to interface controller and android. Controller can be interfaced to the Bluetooth module through UART. According to commands received from android the robot motion can be controlled. The consistent output of a robotic system along with quality and repeatability are unmatched.

Keywords – PIC, Android application, Bluetooth module, Motor driver

I. INTRODUCTION

Nowadays smart phones are becoming more powerful with reinforced processors, larger storage capacities, richer entertainment function and more communication methods. Bluetooth is mainly used for data exchange; add new features to smart phones. Bluetooth technology, created by telecom vendor Ericsson in 1994, shows its advantage by integrating with smart phones. It has changed how people use digital device at home or office, and has transferred traditional wired digital devices into wireless devices. A host Bluetooth device is capable of communicating with up to seven Bluetooth modules at same time through one link. Considering its normal working area of within eight meters, it is especially useful in home environment. Thank for Bluetooth technology and other similar techniques, with dramatic increase in Smartphone users, smart phones have gradually turned into an all-purpose portable device and provided people for their daily use. In recent years, an open-source platform Android has been widely used in smart phones. Android has complete software package consisting of an operating system, middleware layer and core applications. Different from other existing platform like iOS (iPhone OS), it comes with software development kit (SDK), which provides essential tools and Application. Using a Smartphone as the "brain" of a car is already an active research field with several open opportunities and promising possibilities. In this project we present a car controlled by mobile phone and discuss a control systems using audio channels of mobile devices, such as phones and tablet computers.

A. Components Required

Hardware Components: Hardware components comprises of the following:-

- Microcontroller [PIC16F877A]
- Bluetooth HC-05(Master & Slave)
- DC Servo Motor
- DC Geared Motor
- Motor Driver [L293D]
- Smart phone [Android 2.3+]

Software Components: Software components comprises of the following:-

- Mikro C programming software
- Pickit II Programmer
- Tina Industrial Simulator
- Android Studio

B. Introduction to Embedded Systems

1) Definition: Embedded System Any sort of device which includes a programmable computer, but itself is not intended to be a general-purpose computer.

2) What is an Embedded System An embedded system is a microcontroller / digital signal microprocessor based system that is designed to be flexible and built to control or monitor the functions of equipment, machinery, plant and many devices in common use today.

II.METHODOLOGY

A. Block Diagram

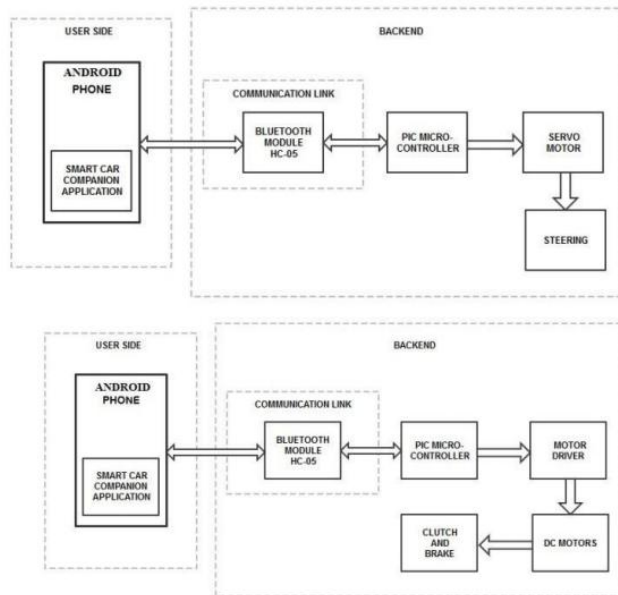

The three main blocks of our project the smart car are a Smartphone employed with the particular android application, a microcontroller unit which is here we use a PIC16F877A, and the output which we obtain from the microcontroller to the actuators like DC motor and servo motor. The Smartphone employed with the android application consist of switches for controlling the steering, clutch and break of the car. As we press the switches commands are sent to the microcontroller unit through the Bluetooth module HC05. The commands sent are in the form of texts like "A", "B" etc. for each switch. For each commands from the Smartphone microcontroller is programmed in such a way to perform specific tasks like rotating motor to a specified direction. For example when we press the button to apply clutch a command "A" is sent to the microcontroller through Bluetooth module and microcontroller programmed in such a way to rotate motor in the direction such that clutch is applied .The output from the microcontroller unit is sent to the actuators with the help of motor drivers. Detailed Description PIC16F877A [Programmable interface controller] PIC is a family of modified Harvard architecture of microcontrollers derived from the PIC1650 originally developed by General Instruments Microelectronics Division. The name PIC initially referred to "Peripheral Interface Controller". Microcontrollers as the name suggests are small controllers. They are like single chip computers that are often embedded into other systems to function as processing/controlling unit. For example the remote control you are using probably has microcontrollers inside that do decoding and other controlling functions. They are also used in automobiles, washing machines,

microwave ovens, toys etc. where automation is needed. Microcontrollers are useful to the extent that they communicate with other devices, such as sensors, motors, switches, keypads, displays, memory and even other microcontrollers. Many interface methods have been developed over the years to solve the complex problem of balancing circuit design criteria such as features, cost, size, weight, power consumption, reliability, availability, manufacturability. Many microcontroller designs typically mix multiple interfacing methods. In a very simplistic form, a microcontroller system can be viewed as a system that reads from (monitors) inputs, performs processing and writes to (controls) outputs.



L293D MOTOR DRIVER

The Device is a monolithic integrated high voltage, high current four channel driver designed to accept standard DTL or TTL logic levels and drive inductive loads (such as relays solenoids, DC and stepping motors) and switching power transistors. To simplify use as two bridges each pair of channels is equipped with an enable input. A separate supply input is provided for the logic, allowing operation at a lower voltage and internal clamp diodes are included. This device is suitable for use in switching applications at frequencies up to 5 kHz.

DC MOTOR

Two DC motors are used to rotate the wheels of the machine simultaneously. Geared DC motors can be defined as an extension of DC motor. A geared DC Motor has a gear assembly attached to the motor. The speed of motor is counted in terms of rotations of the shaft per minute and is termed as RPM .The gear assembly helps in increasing the torque and reducing the speed. Using the correct 3 combination of gears in a

gear motor, its speed can be reduced to any desirable figure. This concept where gears reduce the speed of the vehicle but increase its torque is known as gear reduction. This Insight will explore all the minor and major details that make the gear head and hence the working of geared DC motor. At the first sight, the external structure of a DC geared motor looks as a straight expansion over the simple DC ones. The lateral view of the motor shows the outer protrudes of the gear head. A nut is placed near the shaft which helps in mounting the motor to the other parts of the assembly.

SERVOMOTOR

A servomotor is a rotary actuator that allows for precise control of angular position. It consists of a motor coupled to a sensor for position feedback, through reduction. It also requires a relatively sophisticated controller, often a dedicated module designed specifically for use with servomotors. Servomotors are used in applications such as robotics, CNC machinery or automated manufacturing. As the name suggests, a servomotor is a servomechanism. More specifically, it is a closed-loop servomechanism that uses position feedback to control its motion and final position. The input to its control is some signal, either analogue or digital, representing the position commanded for the output shaft. The motor is paired with some type of encoder to provide position and speed feedback. In the simplest case, only the position is measured. The measured position of the output is compared to the command position, the external input to the controller. If the output position differs from that required, an error signal is generated which then causes the motor to rotate in either direction, as needed to bring the output shaft to the appropriate position.

III. BLUETOOTH MODULE

HC-05 module is an easy to use Bluetooth SPP (Serial Port Protocol) module, designed for transparent wireless serial connection setup. Serial port Bluetooth module is fully qualified Bluetooth V2.0+EDR (Enhanced Data Rate) 3Mbps Modulation with complete 2.4GHz radio transceiver and baseband. It uses CSR Bluecore 04-External single chip Bluetooth system with CMOS technology and with AFH(Adaptive Frequency Hopping Feature). It has the footprint as small as 12.7mmx27mm. Hope it will simplify your overall design/development cycle.

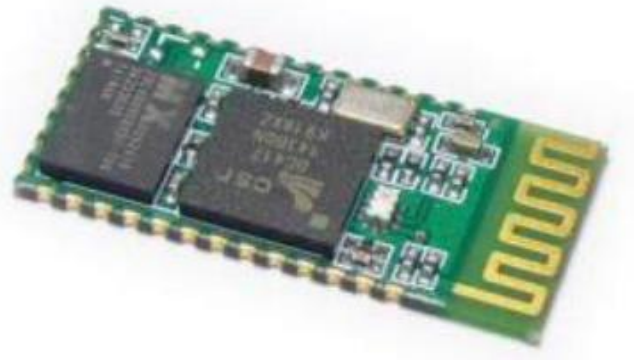

C) ANDROID APP



LOGIN PAGE

The android app to control smartcar is designed with android studio. The app requires password authentication to proceed which makes it highly secure. The app can be used by multiple people once configured. The user can choose to remember his/her login data. The search button allows searching car when it is in 100m vicinity. The left button controls the break and right side button controls the clutch mechanism.

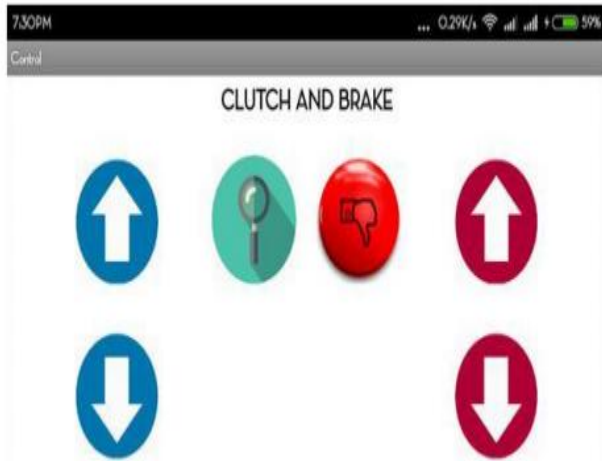

Circuit diagram for clutch and brake control

ADVANTAGES

- Simple to operate.
- Small parking area required.
- Reduce human effort.
- Control car from outside.
- Reduce parking difficulties.
- Easy to control car in off-road.

In future, we will also add more sensors so that car will be automatically controlled auto parking and auto turning. It will also increase the security for the both car and passengers in terrain condition.

IV.CIRCUIT DIAGRAM

V.CONCLUSION

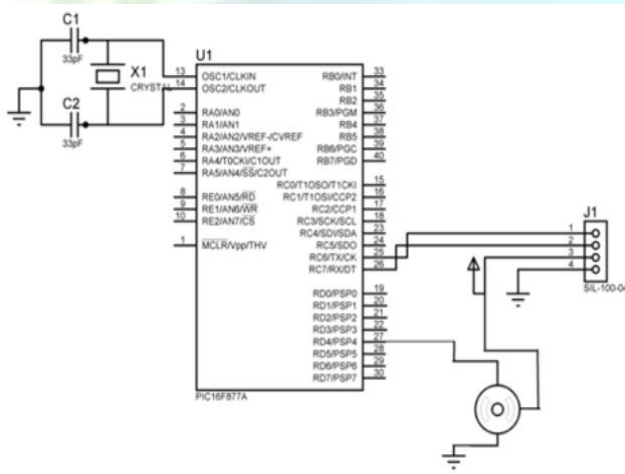

So by doing the project SMART CAR we try to control the car with the help of android application in Smartphone. Thus reducing the effort of controlling car in rough terrain and it also helps in reducing the difficulties of parking a car in tight parking conditions. The communication between the car and Smartphone is done with the help of Bluetooth communication. The commands are sent to the Bluetooth module in microcontroller with the help of Bluetooth in Smartphone.

REFERENCE

Circuit diagram for steering control

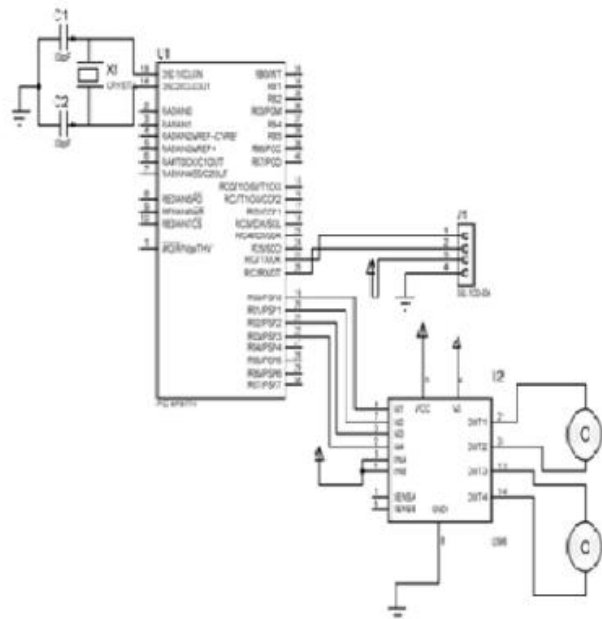

1. [Android Developers Guide. Android Architecture. [Online] 2013. URL: <http://.android.com/about/versions/index.html>.
2. Heidi Monson (1999) Bluetooth technology and implementations, John Wiley & Sons.
3. Piyare, R. and Tazil, M. (2011) "Bluetooth based home automation system using Android phones". IEEE 15TH International symposium on consumer electronics (ISCE), 14-17 June 2011, Singapore.
4. Potts, J. and Sukittanon, S. (2012) "Exploiting bluetooth on android mobile mobile devices for home security application", proceedings of southeastcan, 15-18 March 2012, Orlando, Florida, USA.