

# OBD-II and Oxygen Sensor: Review the I.C Engine - Emissions related Performance

DR. PORAG KALITA, Ph.D. (Auto. Engg.)  
HEAD - Automobile Engineering Department,  
Vocational Education (+2),  
M R S Higher Secondary School, Govt. of Assam.  
Titabor, Jorhat, ASSAM, INDIA.  
Email:poragkalita@rediffmail.com

## 1. Abstract:

Increased awareness regarding the adverse effects of pollutants from automobile exhaust gases has been the main driving force for implementation of more and more stringent legislation on automobile exhaust emissions in many Countries. On Board Diagnostic (OBD), regulations in the USA for light and medium duty vehicles (I. C. Engines) are introducing to implement the air quality standard. California and the Federal Government used a driving cycle to certify 1966 and newer models which referred to as either California Cycle or the Federal Test Procedure (FTP).

The California Air Resource Board (CARB) and the objective to reduce hydrocarbon (HC) emission caused by malfunction of the vehicles emission control systems adopted the California code of Regulations (CCR) known as OBD – II.

The diagnosis is based on the oxygen sensor response time that is the amount of time to complete a switch from rich to lean or lean to rich transition that gives the ability to control the engine at stoichiometric Air Fuel ratio. Typical values of lean mean voltage and rich mean voltage are 300 to 600 mill volts respectively. For post-cat O<sub>2</sub> sensor, in particular, voltage level checks and heater systems checked and done and the failure thresholds for the post O<sub>2</sub> sensor, diagnostic must not be set at a point beyond the failure limit where the catalyst diagnostic is affected.

**Key Words:** Oxygen Sensor, Pre-catalyst sensors, Stoichiometric Air Fuel ratio, Secondary Sensor, Volumetric Efficiency.

## 2. Introduction:

As per Environment Protection Agency, (EPA) USA, and CARB standards the failure criteria for the catalyst monitor diagnostic are the following:

2.1. All pre-catalyst sensors: output voltage and response rate which cause exceeding any of the applicable FTP standards  $\times 1.5$ .

2.2. Secondary sensors located downstream of converter and output voltage or response rate which cause exceeding any of the applicable FTP standard  $\times 1.5$ .

2.3. Heating system: The current and the voltage levels including heater times, and activities that are the warm-up time to move cause exceeding any of the applicable FTP standard  $\times 1.5$ .

The oxygen sensor is use to monitor the residual (after catalyst in the converter) in the exhaust gases. The oxygen sensor output is calibrated to measure the air fuel ratio i.e. proportional to in the oxygen gases) in the engine cylinder and this ratio is called Lambda, as a result, realizing minimum emissions.

### 3. Literature Review:

In our country after spending of lot of money and enacting several statutory laws, the country could not make much headway because several factors. However, problems are still there particularly in maintaining clean air.

OBD-II, in USA for light and medium duty vehicles (I.C.) engines is introducing to implement the air quality standard. In India last 25 years, there has been a rapid increase in number of diesel vehicles. A majority of automotive diesel engine are rated at above 120 Bhp , with the increasing number of diesel vehicles , as a result, the diesel smoke with soot's are come under serve criticism in India.

The diesel engines, all soot's have a graphite structure with hexagonal basis carbon units forming a small crystalline atom. There is a strong suggestion that it is a poly - benzenoid substance, which can cause lung cancer.

The basic reaction of soot's formation is yet unknown, but the following theories are advanced.

3.1. The reaction forming carbon monoxide ( $2C = C + CO_2$ ) is strong catalyzed carbon and when soot's particles are already present in some form; they build up rapidly and then polymerize.

3.2. According to the second theory, the hydrocarbons, especially heavy ends, decompose into simple small basic units of  $C_2$  and  $C_3$  and these small radicals polymerize to form  $C_6$  ring polymers.

A typical reaction is:

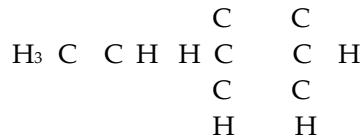

In terms of catalytic soot's filter, adopt programme in India that capture, destroy the black carbon soot's with about 80 to 90% efficiency over 99% of the fine particulate, and destroy the same exhaust components as the diesel oxidation catalyst (DOC) described as better efficiency.

We know that, a hydrocarbon is consisting into four categories:

**Paraffin's:** Paraffin's are saturated hydrocarbons having the formula  $C_2H_{2n} + 2$ . The lower paraffin's are gases, the higher being liquids and still higher is solids.

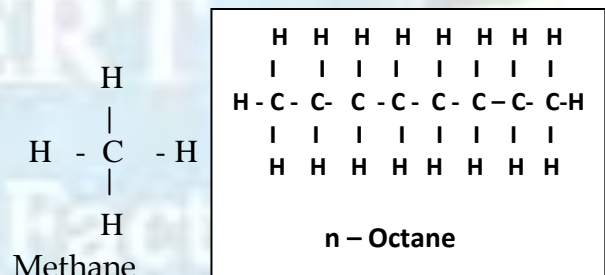

As a length of straight chain increase, the octane number decrease. For example, Octane numbers of normal pentane is 60, where as for normal heptanes in Zero. Branched chain paraffin's have higher octane numbers that their straight chain counterparts. . For high octane numbers  $CO_2$  emission increases and it is not necessary for 2-stroke engine.

**Olefins:** Olefins are the unsaturated hydrocarbons with double bond between some of the carbon soot. Olefins caused HC, it deposits lead to the engine head and hence produce lead smog, it is already been reduced by 30%, from 2005 to 2010, and it has higher anti knock values.

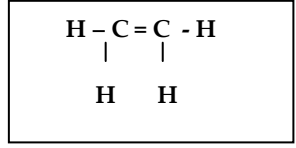

**Aromatics:** Aromatics are the hydrocarbons based upon benzene structure. Aromatics caused increase NO<sub>x</sub> in automobiles. Therefore, aromatics in gasoline reduced from 42% to 35% and in this regard, NO<sub>x</sub> increased 1.6%.

**Napthenes:** There have better antiknock characteristics than the corresponding paraffin's.

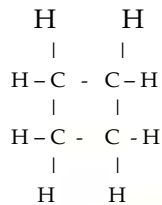

(Cyclobutane)

The over and above, the combustion efficiency of an engine depends upon the shape of its combustion chamber. In India, had already closed the two stroke automobile i.e. Scooter towards emission control programme.

#### 4. Methodology:

The oxygen sensor diagnostics tests do not specify the locations of the oxygen sensors and the names of the sensors located in different exhaust system configurations of engines. The diagnostics is application dependent and is responsible to diagnose the sensors and comply with regulatory standards that include SAE specific malfunction naming conventions and code.

It is the responsibility of the specific application to identify the locations of the oxygen sensors, and their names including their responsibilities such as fuel control, pre-catalyst and post catalyst.

Oxygen sensor diagnostics by Enable Oxygen Sensor:

##### 4.1. Perform O<sub>2</sub> Sensor response tests:

This function checks for any condition that should inhibit the oxygen sensor diagnostic:

The inputs to enable Oxygen Sensor are:

# Intrusive fuel control active state,

- # EGR map Control State,
- # Fault active state,
- # Adaption Control,
- # Air Fuel Control,
- # Idle air state,
- # Idle air control,
- # Inject Control,
- # System voltage, etc.

The output of Enable Oxygen sensor is that Oxygen sensor enabled state (value: true/false).

##### 4.1.1. Operating Status:

Enable Status to True: If the intrusive fuel control state is false, EGR map control state is false, fault active state is false, fuel state is closed loop fueling. In addition, Air fuel control is stoichiometric, idle air state is normal, idle air control is normal, Canister purge control is normal and system voltage is within limits then set the oxygen sensor enabled status to true.

Enable status to False: Otherwise, the above condition does not hold, the oxygen sensor enabled state is set to false.

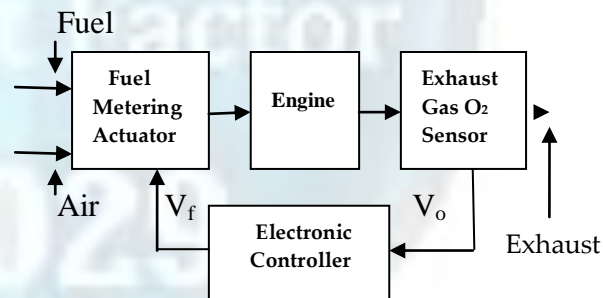

Fig: 4(a) Simplified Typical Closed Loop Fuel Control System

**For example,** the permissible compression pressure for a particular fuel in an engine of compression ratio 7 is 14 kg/cm<sup>2</sup>; find the relative changes in:

- (a) Induction Pressure,
- (b) Volumetric efficiency,
- (c) Air standard efficiency if the compression pressure has to remain the same when the compression ratio is changed to 5.

**Solution:** (a) Let the induction pressure for a compression ratio of = 7 kg/cm<sup>2</sup>.

Assume adiabatic compression =

$$\therefore P_1 V_1^{1.4} = P_2 V_2^{1.4}$$

$$\text{But, } \frac{V_1}{V_2} = 7,$$

$$\therefore P = 14 \times \left(\frac{1}{7}\right)^{1.4} \\ = 0.916 \text{ kg/cm}^2$$

Let,  $P_1'$  kg/cm<sup>2</sup> = Induction Pressure for a for a compression pressure of 14 kg/cm<sup>2</sup> with compression ratio 5.

$$\therefore P_1' = 14 \times \left(\frac{1}{5}\right)^{1.4} \\ = 1.47 \text{ kg/cm}^2$$

$\therefore$  percentage increase in induction pressure :

$$= \frac{P_1' - P}{P} \times 100 \\ = \frac{1.471 - 0.916}{0.916} \times 100 \\ = 60.6 \%$$

(b) Assume that the temperature at the end of compression both the ratio are the same and equal to T and assume that the clearance volume is full of residual gases and hence, the volume of fresh charge admitted will be equal to the cylinder swept volume Vs. ( $\mu$  = Volumetric Efficiency).

Volumetric Efficiency:

$$= \frac{\text{Air Volume reduced to NTP}}{\text{Swept Volume}}$$

$\mu_{v1}$  = Volumetric Efficiency for compression ratio , 7.

$$= \frac{V_s \times P}{V_s \times 1.03} \times \frac{T_0}{T} \times 7^{0.4}$$

Where,  $T_0 = 273^\circ \text{K}$ , and  $\frac{T}{(7)^{0.4}}$  is the suction temperature of Air,

$$\therefore \mu_{v1} = K \times 7^{0.4} \times 0.916$$

$\mu_{v2}$  = Volumetric efficiency for compression ratio 5,

$$= K \times 1.471 \times 5^{0.4} \\ = 2.81 \text{ K}$$

$\therefore$  Relative change in volumetric efficiency = (2.81 - 2) = 2.81 K

$\therefore$  Percentage change in volumetric efficiency =

$$100 \times \frac{0.81 \text{ K}}{2 \text{ K}} \\ = 0.405 \times 100 = 40.5\%$$

$$(c) \mu_{a1} = 1 - \frac{1}{(7)^{0.4}}$$

$$= 1 - 0.4592 = 0.5408$$

$$\mu_{a1} = 1 - \frac{1}{(5)^{0.4}}$$

$$= 1 - 0.5253, = 0.4747$$

$\therefore$  Percentage change in Air Standard efficiency:

$$= \frac{(\mu_{a1} - \mu_{a2})}{\mu_{a1}} \times 100$$

$$= \frac{0.5408 - 0.4747}{0.5408} \times 100$$

$$= 12.23\%$$

## 5. Result & Discussion:

The goal on the OBD is to alert the driver to the presence of a malfunction of the emission control system. The oxygen sensor used to monitor the residual oxygen (after catalyst in the converter) in the exhaust gases. The oxygen Sensor output is calibrated to measure the air fuel ratio (which is proportional to oxygen in the exhaust gases) in the engine cylinders. The ratio called Lambda, is one (1) for stoichiometric (14.7) air fuel ratio. . This is the target for realizing minimum emissions.

The oxygen sensor is use as stoichiometric detection and connected in a closed loop in a limit cycle control. The oxygen sensor output is a switch signal (ON/OFF) that brings back the air fuel ratio to 1 when it varies between 0.93 to 1.07.

### 5.1. MAP Sensor:

Manifold Absolute Pressure (MAP) sensor, the main principle that the sensor measures the displacement of a diaphragm, which is deflect by the manifold absolute pressure.

First Version: In strain gauge MAP sensor, the silicon diaphragm is sealed to a pyrex plate under vacuum. A set of sensing resistors formed around the edge of this vacuum. The resistors are formed by diffusing a, "doping impurity "into the silicon. Manifold pressure applied to the diaphragm cause it to deflect which changes the resistance due to pizoresistivity proportional to the pressure. An electrical signal voltage, which is proportional to the manifold pressure, has been obtained by

Second Versions: A film electrode deposited on the inside face of two alumina plates forming a

capacitor. The capacitor capacitor is placed in a sealed housing that is connected to manifold pressure by a small diameter tube. The deflection of these plates when pressure is applied to them causes their capacitors to change proportional to the applied pressure. The capacitors are placed in an oscillator circuit and the frequency of oscillation is proportional to intake manifold.

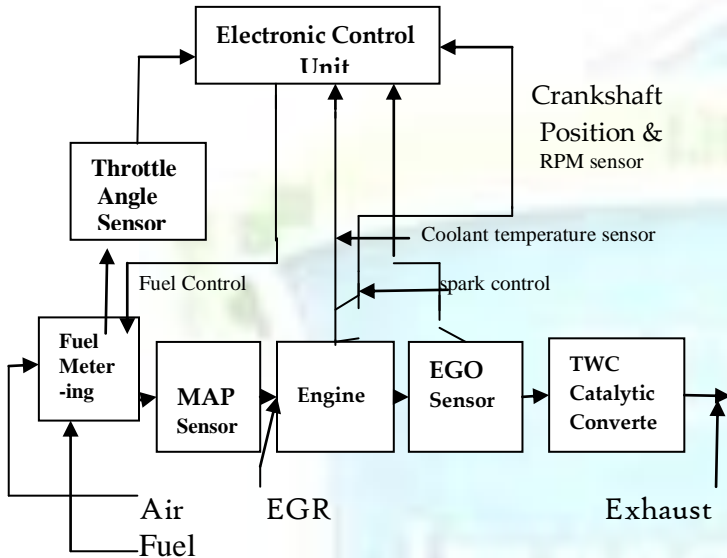

Fig: 5(a) Simplified Block Diagram of Fuel Control System

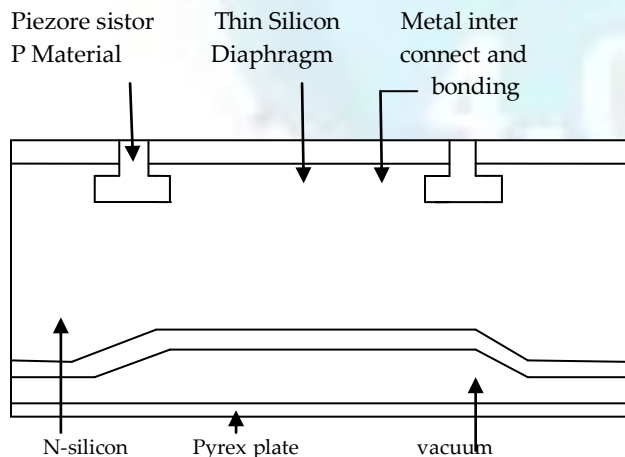

Fig.5 (b) Typical Silicon Diaphragm Strain Gauge MAP sensor

## 6. Type of Data:

OBD-II: STD MANUAL

HS-3000 manual contains is consisting by two sets:

6.1. Diagnostic Committee Documents,

6.2. Multiplex Committee Documents.

6.1. **Diagnostic Committee Documents:**

6.1.1. SAE J 1930 Diagnostics Terms, Definitions, Abbreviations and Acronyms.

6.1.2. SAE J 1962 OBD II Diagnostic Connector,

6.1.3. SAE J 1978 OBD II Scan Tool,

6.1.4.SAE J 1979 Diagnostic Test Modes, 6.1.5.

SAE J 2012 Trouble Code Definition,

6.1.6. SAE J 2186 Data Link Security,

6.1.7. SAE J 2190 Enhanced E/E Diagnostics Test Modes,

6.1.8. SAE J universal interface for OBD II scan,

6.1.9.SAE J 2205 Expanded Diagnostic Protocol for OBD II,

6.2. **Multiplex Committee Documents.**

6.2.1. SAE J 1850 class B DATA communication Network interface.

6.2.2. SAE J 2178 /1 class B DATA Communication Network Messages.

OBD-II, have 10 (Ten) major monitoring requirements and among Nine (9) specific monitors and One (1) catch all. The Nine monitors are:

- (i) Catalyst
- (ii) Heated Catalyst,
- (iii) Fuel System,
- (iv) Misfire,
- (v) Evaporative System,
- (vi) Oxygen Sensor,
- (vii) Air conditioning system (CFC only),
- (viii) Secondary Air System,
- (ix) Exhaust Gas Re-Circulation, etc,

OBD-II has to communicate the diagnostic information to the vehicle mechanic via communication network using diagnostic trouble code (DTCs).

A special connector, SAE J 1962 is used to facilitate the interface for communication. The mechanic uses scan tool, SAE J 1978, for collecting diagnostic message from the vehicle. The HS-3000 manual, and SAE standard tools; and every SAE standard specifics one particular component for compliance.

7. Conclusion or Main finding:

Attention has been drawn into the gasoline direct injection (GDI) engine due to various potential advantages. GDI engine provide various advantages, including precise control of fuel injection to each cylinder in each cycle and the capability of producing stratified charge lean – burn combustion with fully un-throttled operation. Especially, viable one GDI engines that have been introduced since 1996, which have overcome problems of earlier GDI system based on diesel – injection systems will advanced – computer- controlled fuel injection system. In cylinder direct injection of fuel allows two different combustion strategies to be used:

7.1. The simplest method is to produce a homogenous charge by injecting the fuel during the intake stroke to allow enough time for fuel vaporization and mixing. Load Control is achieved via throttling.

7.2. Direct injection stratified –charge (DISC) engines, in which compact fuel rich clouds is formed around the spark plug in an

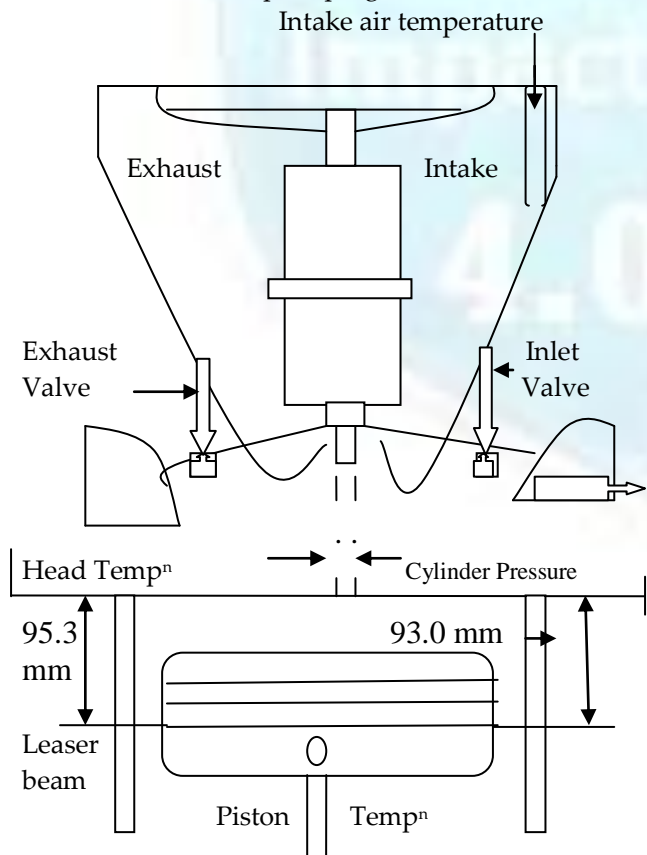

Fig: 7(a) Combustion Chamber  
 With DI System:

Overall lean mixture. Spark ignition is used to intake combustion both GDI strategies and can be adjusted for various engine speeds and loads by a computer based control system. The full potential of the GDI combustion systems requires use of both GDI strategies.

The current emission legislation i.e. OBD – II, tests all sensors, actuators (valves) , switches and wiring for proper connectivity and checks the inputs and output of each are within allowed range of value. Each sensor circuit consists of mainly three parts, i.e. sensor, signal processor and a display device.

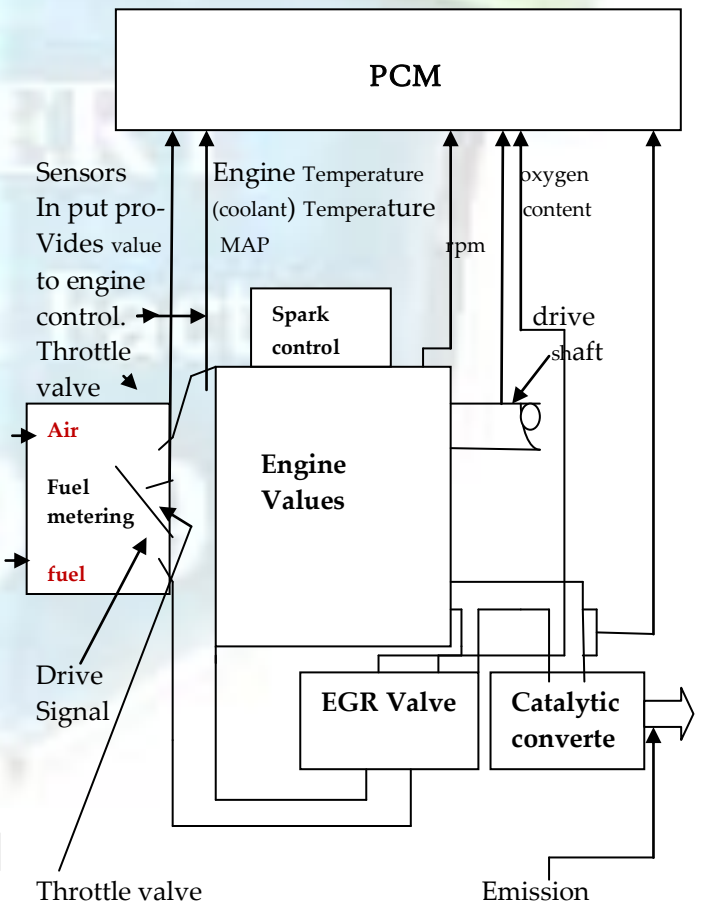

Fig:7(b) Major Controller inputs from Engine. Oxygen sensor and Heater, monitoring for the performance of oxygen sensor, while it's operating temperature maintained within a

specific range above 260° C. For this reason a heater is used to keep the oxygen sensor temperature at the desire value However, fuel injection system plays an important part in supplying the required air fuel mixture to a spark ignition engine for improving mixture preparation contributes to an enhanced power and fuel economy. The engine port injection mode performance at here different throttles openings over a wide range of engine speed. At 50% and 20% open throttle position as compared to wide open throttle position there is a fall in engine performance and increase in CO and HC emissions. Therefore, exists a significant improvement in engine performance and emissions characteristics operating automatic control as compared to the manual control of the systems throughout the range of engine operating parameters.

Therefore, OBD-II diagnostic requires that the heater of the oxygen sensor must be monitored periodically for its normal operation. The circuit continuously checked, the voltage across the heater is checked; the normal current carried by the heater element is checked (Max. 20 A) as well as, the temperature of the oxygen sensor. If the heater found defective on any of three accounts, the PCM sets a fault code. The PCM has a special circuit for detecting short circuit (break) of the sensor wiring and monitoring the switching frequency, which is controlled by Relay.

#### 8. Acknowledgements:



I would like to thank the many people who helped and supported with this work, and received considerable tutorial information from SAE International Conference & Exposition and

SAE International Workshop, and the others engineering colleges in India.

#### 9. References:

- [1] *Proceeding of SAE International Total Life Cycle Conference & Exposition in Michigan, USA, 2000.*
- [2] *SAE paper no. 2000-01-1477 by Dr. Porag Kalita, M R S Higher Secondary School, Titabor, Assam, India.*
- [3] *Seminar On Board Diagnostics – II, by Prof. S. Ganeshan, Oakland University, USA/2000.*
- [4] *SAE paper No. 2000-01-1417 by Sivanadi Rajadurai and M. Tagomori, USA*
- [5] *SAE paper No. 2000-01-1476, by Dr. Randolph E, Massachusetts Institute of Technology, USA.*
- [6] *P. Kalita (2005), paper presented at UGC sponsored National Seminar, Chemistry Department, Guwahati University, India, 28<sup>th</sup> to 29<sup>th</sup> January.*
- [7] *P. Kalita (2011), paper presented at UGC sponsored National Seminar, Chemistry Department, Dibrugarh University, India, 10<sup>th</sup> to 12<sup>th</sup>, January/11.*
- [8] *P. Kalita (2002), paper presented all India Seminar by Institutions of Engineers (IE), Guwahati chapter, May 31<sup>st</sup>. 2002, Mechanical Engineering Department, Kolkata.*
- [9] *P. Kalita (2006), paper presented at the UGC and ICSSR sponsored National Seminar, R M College, Silchar, Assam, India, Feb 6<sup>th</sup> to 7<sup>th</sup>/2006.*
- [10] *P. Kalita (2006) paper presented at N.L College, Assam, India, at Ministry of Environment & Forests , N. Delhi Sponsored Nat'l Seminar , January 28<sup>th</sup> to 29/2006.*
- [11] *P. Kalita (2015), paper presented at National Conference by Dr. K V Subha Ready Institute of Technology, Kurnool, April 25<sup>th</sup>/2015., paper I/D 1505001.*
- [12] *P. kalita,(2015), paper presented at National Conference by Kongunadu College of Engineering & Technology, Trichy, 25<sup>th</sup> march/2015, Paper I/D 20150403165.*
- [13] *P. Kalita (2016), paper in International Conference in Indian Institute of Chemical Engineer, Haldia, I/D OP-ABS-ED-100, dated 21<sup>st</sup> to 23<sup>th</sup>, January/2016.*
- [14] *P. Kalita (2016), paper in Ambalika Institute of Management and Technology, Luck now, I/D COTii/ME/16001, dated 19<sup>th</sup> to 20<sup>th</sup> Feb/2016.*

#### Edited Book

- [15] P. Kalita, *Automotive Service Business, 1st Edition, Volume I*, 2007.
- [16] P. Kalita, *Catalytic Converter Design and Development, volume I*, 2015.
- [17] P. Kalita. *Automobile Emission Control and its Servicing, 1st Edition, Volume I*, 2013.

#### Journal

- [18] P. Kalita (2015), Paper published online *International Journal* ([www.ijcert.org](http://www.ijcert.org)), I/D V2-106-02, Volume-2, Issue – 6, pages from 403 to 411, 2015.
- [19] P. Kalita (2015), paper published online *International Journal* ([www.ijret.org](http://www.ijret.org)), I/D 20150401061, pages from 459 to 465, Volume 4, Issue 2, February/2015.

## 10. Definition/Acronyms/Abbreviation

### Definition:

**Air Injector:** This system of injecting fuel, into the combustion chamber of a diesel engine using a blast of compressed air.

**Pintle:** A small extension of the needle valve tip projecting through the discharge nozzle. When the needle lifts, the oil passes through the opening between the circumference of the orifice and that of the pintle.

**Smog:** A term coined from the words, "Smoke" and "fog", first applied to the froglike layer that hangs in the air under certain atmosphere conditions. Now, generally used to describe any a condition of dirty air and or fumes or smoke.

**Throttle valve:** The butterfly valve of a petrol engine.

**Thrust:** axial force acting on a shaft.

**Volumetric Efficiency:** Ratio of the volume discharged from a pump to the piston displacement of the pump. In diesel engines a term often used instead of the correct term 'charge efficiency'.

**Idle Air Control valve (IACV):** The valve is an electronically controlled throttle by pass valve which allows air to flow around throttle plate (which is closed due to low engine rpm and vehicle being stationery) and produces the same effect as if the throttle slightly opened.

**Solenoid:** A type of electro-magnet often used to operate the starter motor switch.

### Abbreviation

CARB = California Air Resource Board.  
CCR = California Code of Regulations.  
DTC = Diagnostic Trouble Code,  
FTP = Federal test Procedure.  
I.C. ENGINE = Internal Combustion Engine.  
MIL = Malfunction Indicator Light.  
MAP = Manifold Absolute Pressure

### Acronyms